

SPECIFICATIONS: HEAVY DUTY 36" / 48" HULLER

1] MAIN DRIVE MOTOR - 25HP 1450/1750RPM, 380/230/440V 50/60HZ

2] HYDRAULIC MOTOR - 2HP 1000/1200RPM, 380/230/440V 50/60HZ

3] FEEDER MOTOR - 1HP 90V DC

4] BELTS - PRIMARY 5V-6 GROOVE - SECONDARY "CC" - 4 GROOVE

5] REPLACEABLE HULLER KNIVES 19 PER CYLINDER 38 TOTAL

7] HYDRAULIC SAFETY ROLL RELIEF SYSTEM

8] DUAL 18" DIA. X 36" HULLING CYLINDERS

9] SHIPPING WEIGHT: 7800 LBS / 3538 KG

10] SHIPPING VOLUME: 160 FT³ / 4.5 M³

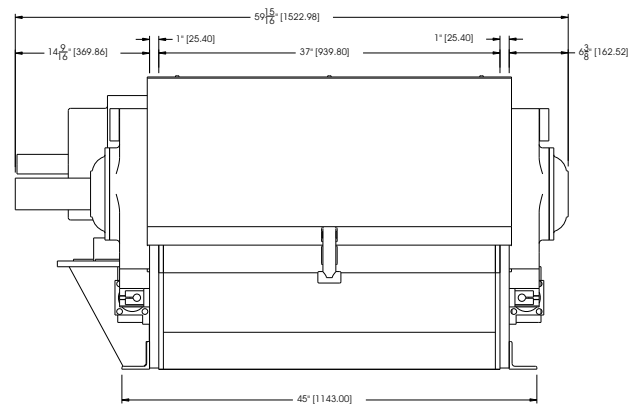
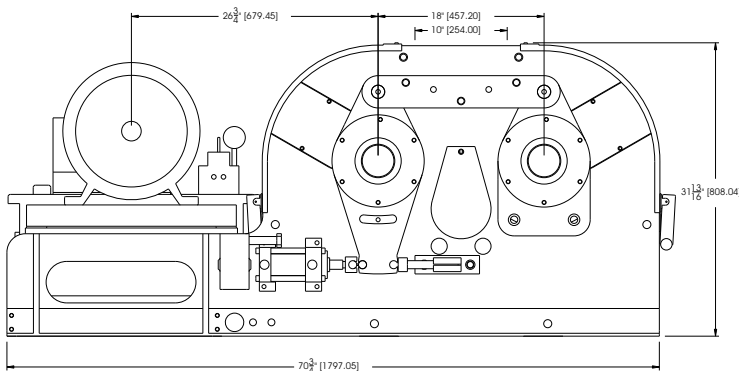
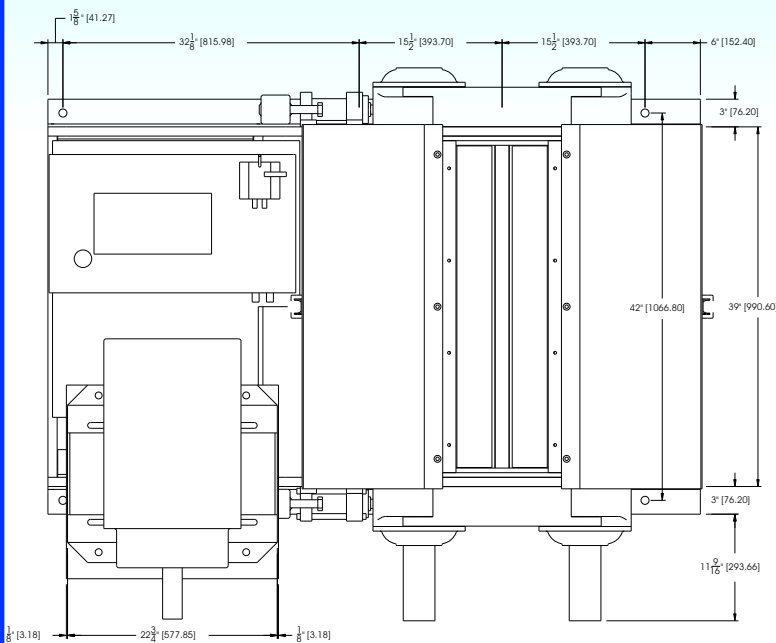

THE 36" TWIN ROLL HULLER & BASKET BEATER / SHAKER IS PRIMARY TO PRODUCE HULLS WITH A MINIMUM OIL CONTENT BY EFFICIENTLY BEATING THE HULLS TO REMOVE THE HIGH PROTEIN FINISHED MEATS.

THE COMBINATION CONSISTS OF AN 36" TWIN ROLL HULLER, EIGHT-CHAMBER BEATER SECTION MOUNTED ABOVE A SHAKER SEPARATOR TRAY.

WHEN TEAMED UP - you have the most efficient seed hulling & primary removal of hulls from oil bearing seeds on the market today.



CANTRELL WORLDWIDE (INDIA) PVT. LTD.

706, Acme Plaza, Opp. Sangam Talkies, Andheri-Kurla Road, Andheri (East), Mumbai-400 059. (India)

Tel. : +91-22-2826 4201/2/3/4 • Fax : +91-22-2834 6161

E-mail : cantrellworldwide@vsnl.net • www.cantrellworldwide.net